

THE FALCO 600 IS FM APPROVED FOR INSTALLATION IN CLASS 1, DIVISION 2 GROUP D, (TEMP CODE T2C) HAZARDOUS LOCATIONS EXTENDING UP TO 30 INCHES FROM THE BOTTOM OF THE FRAME.

FIGURE 1B: FALCO 600 with VFD, MAJOR COMPONENTS

REV 11-5-10

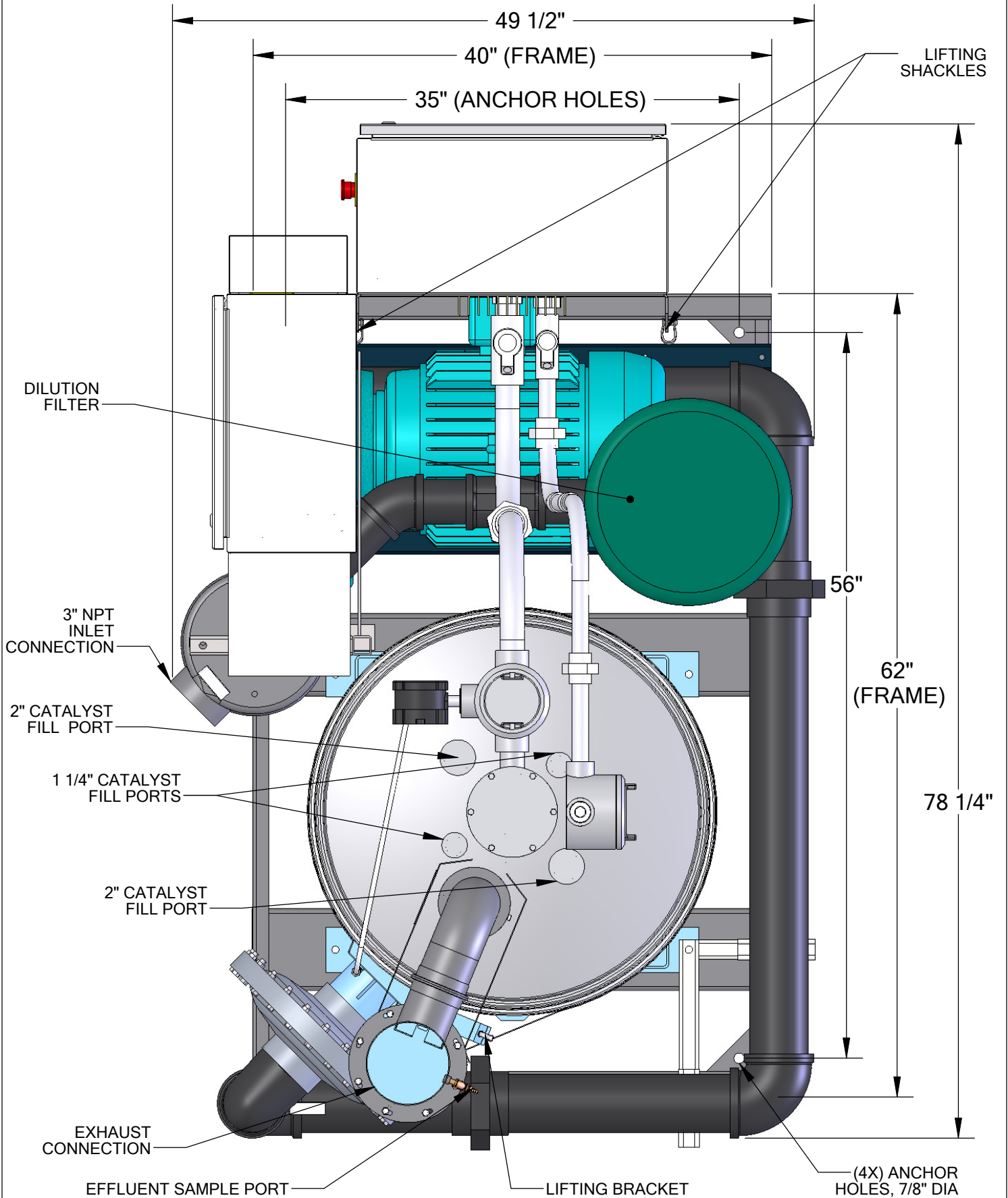

FIGURE 2B: FALCO 600 with VFD- TOP VIEW